

Hybrid Drive For Vehicles

Khadeev R.G.

State Research and Test Institute of Military Medicine, Moscow, Russia

Abstract—In the article proposes a simple construction of the transmission for a hybrid vehicle allowing in a wide range of automatically change of the torque of the driven shaft and the gear ratio from the engine to the driven wheels.

Keywords—Asymmetrical differential, torque, gear ratio, electric current generator, slip clutch, electromagnetic clutch.

I. Annotation: Mechanical hybrids cannot compete with electric hybrids because of the impossibility of creating adaptive transmissions capable of operating in a wide range of gear ratios (more than 20). For radically, simply and cheaply the overcome this problem, it is proposed an innovative solution: The mechanism described in the patent application number 2016145874 from 22/11/2016.

Description of the mechanism: It has two of sequential asymmetric differentials is connected with special mechanism which partially is blocking its operation. In the first case the differential is connected to an electric current generator and in the second case with the mechanism of slip clutch. The same device serves to connect to the wheels of electric motors which are not connected to the main transmission. This will allow to change in over a wide range of torque and gear ratio at the output, in the automatic mode depending resistance at optimum engine speed. Differentials have input and two outputs, which divide the engine power into two streams and transmit a different torque. Input of the first differential connected to a motor. One output that transmits more torque is connected to the output shaft of the mechanism, and a second output coupled to the stator of the generator, the rotor of which is connected to the input of the differential. The stator of the generator is rotatable together with the second differential output around its axis. The stator with rotor forms an electrical machine dual rotation [1]. The second output of the differential is also connected with a controllable coupling, which is connected to the housing with the response part. The coupling has the ability to stop the second output with the stator of the generator, connecting it to the housing. From the output shaft of the first differential the rotation is transmitted to the input of the second differential device, which plays the role of the clutch mechanism, and also allows to increase at the output of the torque [2]. Both outputs are also located concentrically on a common axis.

A first differential output connected to driven shaft and the second output is connected with the slip coupling. The second part the coupling is connected to the input of the differential. The rotation of the motor is transmitted to the generator rotor and to the input of the first differential, then through its elements to the output shaft of the first differential which rotates in the same direction. The second differential output connected to the stator of the generator,

which tends to rotate in the direction opposite to the direction of rotation of the generator rotor. If there is an electrical load between the stator and the rotor arises the force. The stator pulls behind the rotor. This partially blocks differential, causes it to rotate around its axis, reduces the transmission ratio, increases the rotational speed of the driven shaft. When controlling the load in generator circuit, can be controlled the speed and torque of the output shaft. If necessary, the second output of the differential is stopped by connecting it to the housing, making from the differential the reducer. In this case generator stator is stopped by. Since the generator is a reversible electric machine, it can be used to start the engine, and for increasing of acceleration of the vehicle when starting to move or for the move on electric traction.

From the output shaft of the first differential the rotation is transmitted to the input of the second differential, one output of which is connected to the driven shaft, and a second output connected to a controlled clutch, the retaliatory disc which is connected to the input of the second differential, it during acceleration, partially blocking the differential while reducing its total ratio. When the movement is transmitted through elements of the differential, then the ratio of the mechanism is maximum, torque on the driven shaft also maximum. It increases the torque the multiple. When the clutch does not slip, the differential is completely locked, the transmission ratio equal to one, the output torque equals a torque at its input. The clutch is not directly is connect the input and output shafts. The differential only controls the operation of the mechanism. The electric current produced by the generator, when controlling the operation of the first differential mechanism is applied to motors is not connected to the vehicle drive elements, such as wheels, not connected to the driven shaft of the transmission. These motors are connected with the wheels through a device consisting of an asymmetric planetary differential gear and connected thereto an electromagnetic clutch. The motor shaft is connected to input of the differential and an anchor of electromagnetic slip clutch. One output of the differential being connected to the driven shaft and the second output is connected to the inductor of the electromagnetic clutch.

The second output of the differential seeks rotate in the opposite direction relative to the direction of rotation of the engine and the first output of the differential, but by the force of electromagnetic induction arising between the armature and the inductor partially blocks the differential and reduces overall gear ratio, the driven shaft is accelerated. When the load increases, the slip increases of the between armature and the inductor, and in greater degree the rotation is transmitted through the differential gear, rotation around its axis slows. Gear ratio to the driven shaft increases. Shaft speed is decreases and the torque increases. At a constant speed and torque the armature of the motor, the rotation of the output shaft and torque automatically, vary widely. Values of the parameters are

determined by the parameters of the differential. At the start the gear ratio

from the motor to the driven wheel is maximum. The torque of the output shaft is multiple exceeds of the engine torque. At the Fig. 1 shows a first differential mechanism connecting the vehicle engine to the generator:

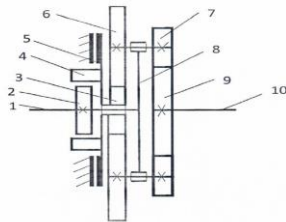

1. Engine shaft. 2. Generator rotor. 3. Central gear of the differential. 4. Generator "stator" winding. 5. Link. 6,7. Satellites. 8. Carrier. 9. Second central gear. 10. Driven shaft

Fig,1

The shaft of the engine 1 connected to the rotor of the generator 2 and with the carrier 8. When the first differential is rotates, the drive shaft transfers the engine power via satellites 6 and 7 is connected to each other, and installed and freely rotating on a carrier 8, to a central wheel 9 and to the central wheel 3. The stator generator 4, which is connected to the central wheel 3, and can rotate with it about the axis. When there is load on the driven shaft 10, the center wheel 3 will tend rotate in the direction opposite to the rotation of the drive shaft 1. If electrical load is included in the network of the generator, there is the force of electroinduction. which pulling the generator stator 4 and the central wheel 3 behind the rotor of the generator 2 and partially blocking the differential, increasing the speed of the its rotation around its axis, reducing the overall gear ratio and increasing the rotational speed of the driven shaft 10. By varying the electrical load in the generator circuit we can control the transmission ratio and the torque on the driven shaft. Coupling 5, if necessary, connects the stator of the generator to the housing and the stator is stops its rotation, which makes it possible to use the generator as a motor.

Figure 2 illustrates a second asymmetrical differential. This planetary gear, is connected to the slip clutch.

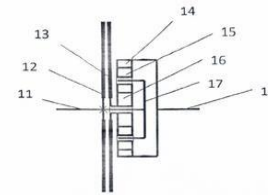

11. Input shaft. 12. Disc of input of the clutch. 13. Mating disc of the coupling. 14. Crown of the planetary gear. 15. Satellites. 16. Central gear. 17. Carrier. 18. Driven shaft.

Fig.2

The rotation of the shaft 10 of the first differential mechanism is served to the input shaft 11 through, on the carrier 17. The shaft 11 is also connected to the input of the clutch 12, the mating part which 13 is connected with one of the outputs of the differential, with a central pinion 16. The rotation is transmitted via the satellites 15 on the crown of the planetary gear 14 and further to the output shaft 18. When the shaft 11 rotates, the shaft 18 will rotate in the same direction, but the central wheel 16 with the slip of the clutch will tend to rotate in the opposite direction. If no slipping in the clutch, the differential rotates about an axis and all the pinions are fixed relative to of each other, the gear ratio of the mechanism is equal to unity. If there is slippage, the rotation from the shaft 11 on the shaft 18 is partially transmitted through the gears, the gear ratio of the driven shaft is increases in proportion to the parameters of the planetary gear, the output shaft 18 is slowed down, and the torque from shaft 11 to shaft 18 proportionately increases. Connecting directly to the wheel motor through a mechanism consisting of an asymmetric differential and electromagnetic clutch is invited as element of the transmission [3]. The mechanism may be disposed in the motor housing, in its own housing, or inside the wheel. Fig.3, for example, shows a mechanism disposed within the wheel.

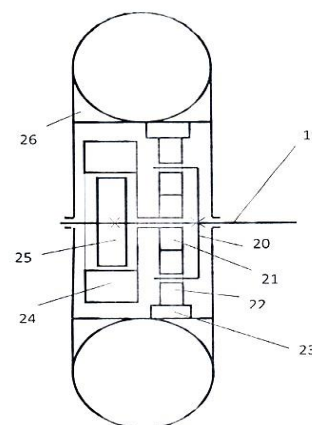

19. Motor shaft. 20. Carrier. 21. Central wheel. 22 Satellites. 23. Crown. 24. Inductor. 25. Armature of the electromagnetic clutch. 26. Wheel.

Fig.3

The motor shaft 19 is connected to the planetary carrier 20, satellites 22 are connected to the central wheel 21 and to the crown 23 connected to the vehicle wheel 26. The center wheel 21 is rigidly connected to the inductor of the electromagnetic clutch 24. The inductor and the center wheel rotates freely on the shaft. On the shaft 19 is also mounted and connected with it rigidly the armature of the electromagnetic clutch 25. It is connected to the inductor 24, by the electromotive force. Upon rotation of the motor shaft 19, the crown of the planetary gear 23 and the armature of the electromagnetic clutch 25 rotate in the same direction, but the center wheel 21 with the inductor 24 tends to rotate in the opposite direction. The power of induction it occurs when there is the mutual rotation between the armature and the inductor. The inductor pulls behind itself a central wheel, associated with it and partially blocks the differential, causing the wheel is accelerated. During braking of the wheel 26, at constant speed motor, the slip between the inductor 24 and the armature 25 increases, the rotation transmitted largely through the transmission gear 21, 22 and 23, and the gear ratio is automatically increased, the torque is increased also.

Conclusion: All are three out of proposed the transmission mechanisms is of the same type and similar [4]. They are simple and therefore reliable. They allow to change at wide range automatically, depending on the load, the gear ratio and torque. At the same time the engine speed may remain constant and optimal.

REFERENCES: [1]R.G.Khadeev (2011) Electric Motor with Controllable Speed and Torque, Russian Engineering Research,1,13-14

[2] R.G.Khadeev (2012) Coupling with an Asymmetric Differential. Russian Engineering Research, 6,723–724. [4] R.G.Khadeev (2011)

[3] R.G.Khadeev (2010) Smooth Starting Mechanism, Russian Engineering Research,8,807-808

[4] R.G.Khadeev (2014) Hybrid drives. Vestnik Mashinostroeniya. 1, 87-88